



**RGB Technology**<sup>®</sup>  
MODERN TECHNOLOGIES

# OPERATION AND MAINTENANCE MANUAL

ZB20 CLOCKS in the Prestige line casing

Product code:

- 301-09-01
- 301-09-02
- 301-09-03
- 301-09-04
- 301-09-05
- 301-09-06

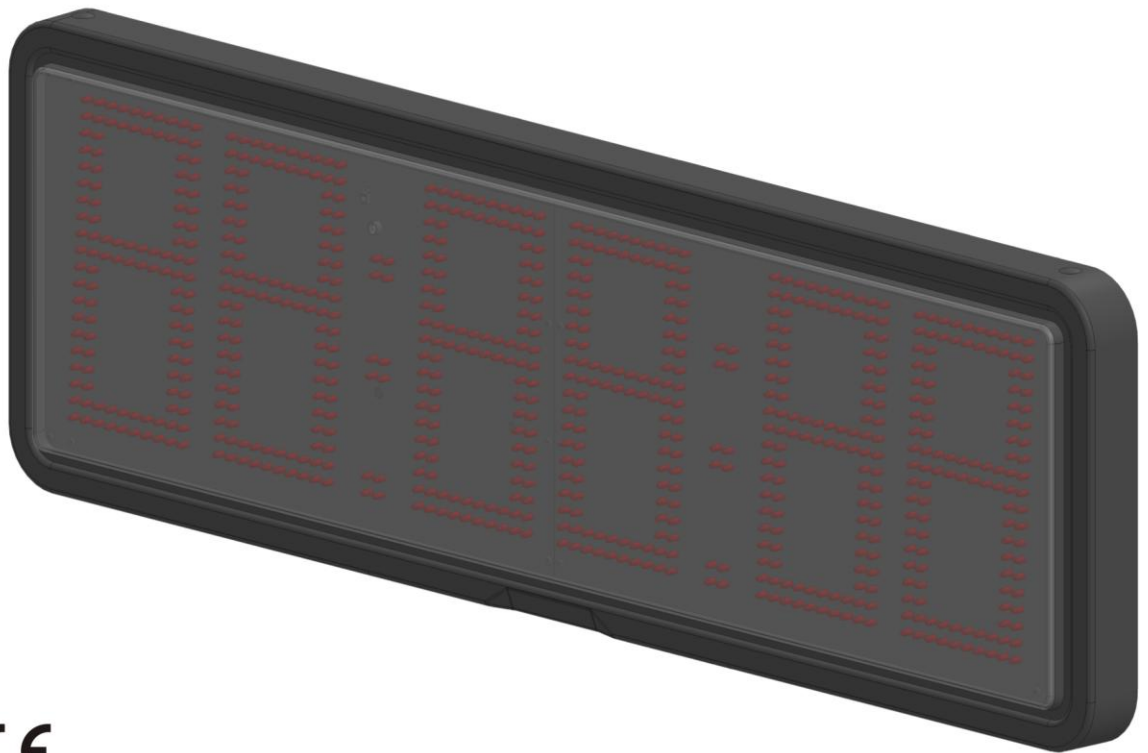

\* Explanatory figure

## Table of contents

1	Manufacturer .....	3
2	Specifications .....	3
3	Transport and storage .....	3
4	Device construction .....	3
4.1	Construction of the ZB20 clocks .....	4
4.1.1	List of display cables.....	4
4.2	Dimensions of the ZB20 device.....	4
4.2.1	Mounting the ZB20 device .....	4
5	Installation of the device .....	5
5.1	ZB20 devices .....	5
5.2	ZB20 configuration.....	5
5.2.1	Configuration of the device through the embedded website - Web panel .....	5
6	Compact-clock extender module.....	5
6.1	Description of the compact-clock extender connectors.....	6
7	Automatic brightness control of the device .....	6
8	Executive relay module .....	6
8.1	Executive relay parameters .....	6
9	Additional options .....	7
9.1	IR remote control unit .....	7
9.2	PoE power supply .....	7
9.3	GPS module.....	7
9.4	Temperature sensor .....	7
9.5	Audible signalling device.....	7
10	Initial start-up .....	7
11	Disposal and recycling .....	8
11.1	Recycling of packing materials.....	8
11.2	Disposal of the device.....	8
12	Most common installation errors .....	8

## 1 Manufacturer

RGB Technology Sp. z o. o.  
 Tymień 18  
 76-035 Tymień  
 POLAND

## 2 Specifications

### ZB20 clock

Dimensions of the device [mm]:	900 x 288 x 45
Display format:	HH:MM:SS
Permissible input voltage range (long-term):	100 ÷ 240 VAC
Permissible input voltage range (short-term):	85 ÷ 264 VAC
Acceptable input voltage frequency range:	47 ÷ 63 Hz
Control method:	IR remote control unit <sup>1</sup> / Web Panel
Digit height [mm]:	200
Casing tightness rating <sup>2</sup> IP:	66
Weight of the device:	4kg
Average power consumption of the device:	20W
Device operation temperature (ambient):	-25°C ÷ 45°C
Device operation temperature (device surface)	-25°C ÷ 60°C

Available LED colours with their catalogue index number:

Catalogue index number	Colour
301-09-01	Red
301-09-02	Green
301-09-03	Blue
301-09-04	Yellow
301-09-05	Amber
301-09-06	White

Table 1

## 3 Transport and storage

Care should be taken to properly protect the devices so as to eliminate any damage during transport. It is forbidden to transport the devices in a collective package without adequate amortisation - each device must be packed separately and cannot have freedom of movement during transportation.

Due to the protective packing the module should be stored in the temperature not lower than -20°C and not higher than +60°C at the humidity below 99%RH.

## 4 Device construction

ZB20 has a housing made of polycarbonate, which is resistant to UV radiation and has a high mechanical strength. By using the thermo-moulded housing and a rear sealing layer, the device, when properly assembled, meets the IP66 tightness requirements.

<sup>1</sup> IR control module optionally available.

<sup>2</sup> Specified on the basis of EN 60529.

## 4.1 Construction of the ZB20 clocks

The figure shows ZB20 clock<sup>3</sup>.

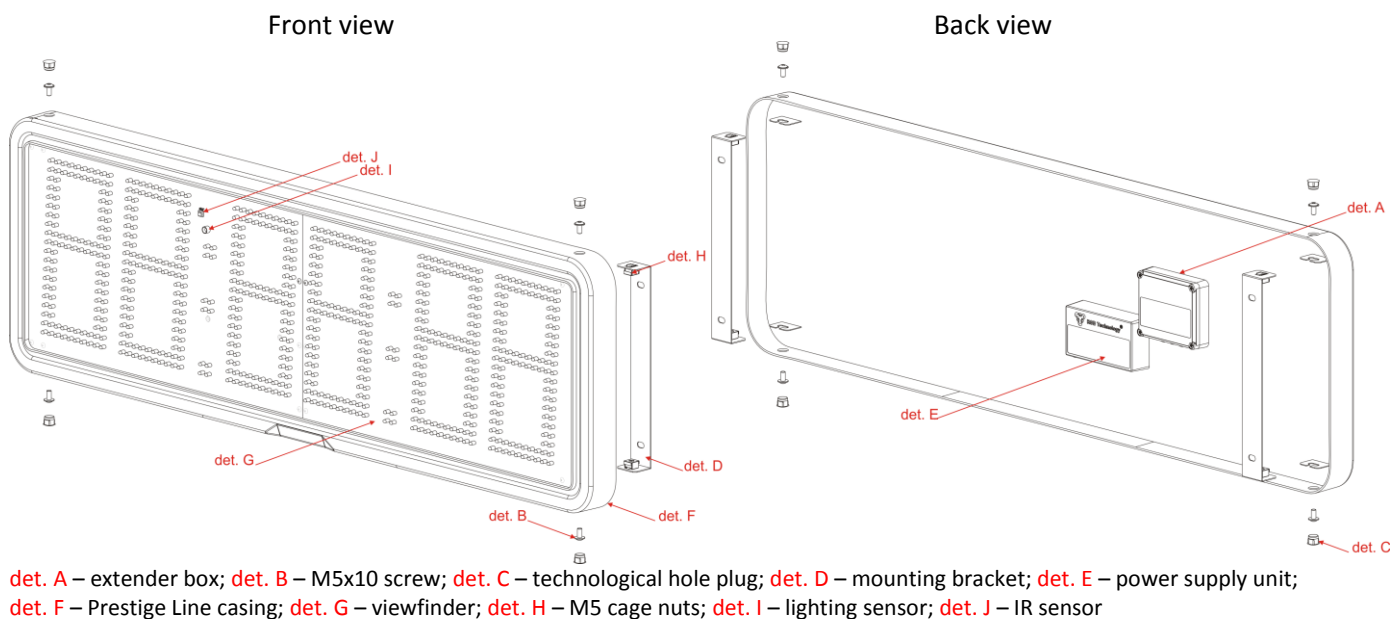

Fig. 1

### 4.1.1 List of display cables

1. Two-metre power cord (2 x 0.5mm<sup>2</sup>), terminated with power plug,

## 4.2 Dimensions of the ZB20 device

All the dimensions shown in the drawings are given in [mm].

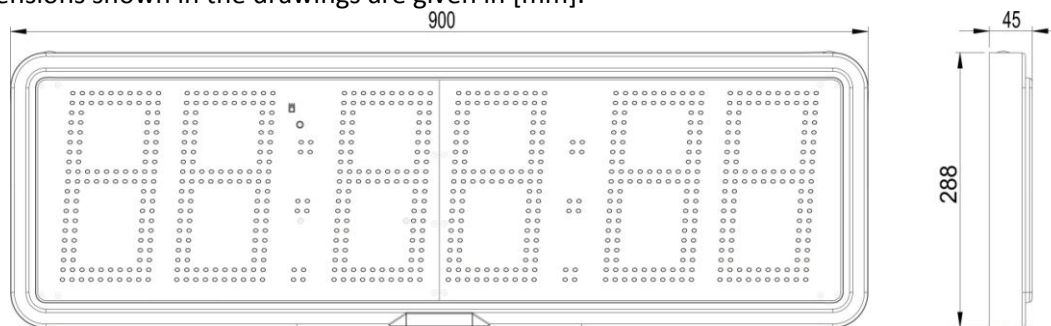

Fig. 2

### 4.2.1 Mounting the ZB20 device

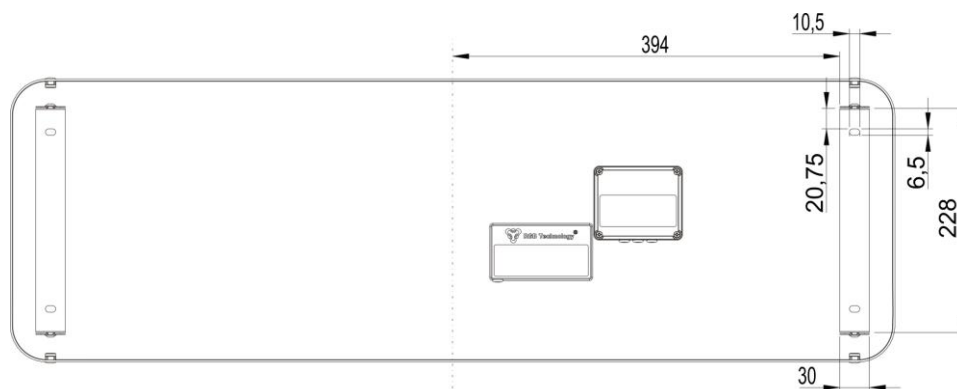

Fig. 3

<sup>3</sup> Explanatory figure.

## 5 Installation of the device

Proper installation consists in mounting the device on a flat surface with the leads facing down. Only the correct installation of the device ensures its proper operation and maintaining the device parameters, e.g. casing tightness rating to satisfy the IP code.

### NOTICE!

Before any installation or maintenance operations refer to the manual supplied by the manufacturer. Improper connection to the mains power supply, incautious device installation, or improper use may cause the property damage, loss of health or death from electrical shock! In addition, any failure to follow the manufacturer's instructions may void your warranty.

### NOTICE!

Keep in mind that all the components must be mounted with the leads facing down.

### NOTICE!

It is forbidden to make any additional mounting points or any holes in the device assembly components.

### 5.1 ZB20 devices

The ZA20 devices are designed to display time, date, and optionally temperature. For the proper operation of the device, it should be correctly configured. As a standard the device is configured using LAN.

### 5.2 ZB20 configuration

The configuration process consists in personalising the device through the embedded Web panel. The user, after connecting the clock through the LAN interface, can edit the display parameters of the clock.

#### 5.2.1 Configuration of the device through the embedded website - Web panel

To connect with the clock, first you should configure the network card of the computer to which it is connected. The proper configuration of the network card can be downloaded from <http://rgbtechnology.pl/soft/>. Having configured the network connection correctly, you can, through a Web browser, connect with the embedded website (Web panel), where you can personalise the device. On the embedded clock website, you may use the following tabs:

- TIME -> tab allowing you to configure the parameters connected with time;
- DISPLAY -> tab allowing you to configure the parameters connected with the device display;
- ALARMS -> tab allowing you to configure the parameters connected with alarms (option available in the version with an audible signalling device);
- ADVANCED -> tab allowing you to configure the advanced parameters of the device;
- STATUS -> tab allowing you to read the device status.

The detailed description of the tabs is available in the device operation manual `instr_hardware_037`.

## 6 Compact-clock extender module

The extender module (Fig. 4) enables the operation of peripheral devices and, thanks to a battery, ensures correct time counting when there is no external power supply.

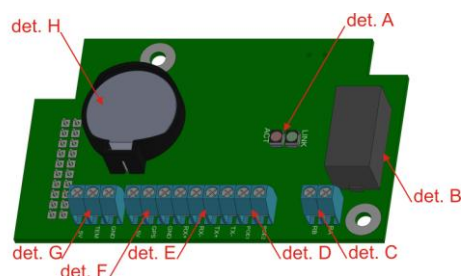
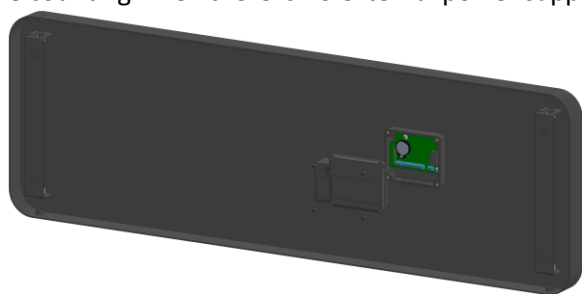

det. A signal LEDs; det. B – relay; det. C – relay connector; det. D – PoE output ; det. E – LAN connector; det. F – GPS connector; det. G – temperature probe connector; det. H – battery

Fig. 4

## 6.1 Description of the compact-clock extender connectors

Symbol	Function	Remarks
RA, RB	Relay (alarm signalling device)	Closing contact, normally open; permissible load: - resistive: 5 A 250 VAC, 5A 30 VDC - inductive: 2 A 250 VAC, 2A 30 VDC
TX+	Ethernet	Pin no. 1 plugs RJ-45
TX-		Pin no. 2 plugs RJ-45
RX+		Pin no. 3 plugs RJ-45
RX-		Pin no. 6 plugs RJ-45
POE1, POE2	Linie PoE (Power over Ethernet) lines	According to the IEEE 802.3at standard (PoE+ active power supply)
GPS	GPS module signal	Cooperates with GPS GM-2
TEM	Thermometer	–
5V	Power supply for external modules	Power supply for GPS and thermometer
GND	Mass of the system	–

Table 2

## 7 Automatic brightness control of the device

In the standard version, a lighting sensor is included. The device, in response to the intensity of daylight, adjusts the brightness of the clock display.

## 8 Executive relay module

The device is equipped with an embedded executive relay, which enables signalling up to 30 alarms. The duration of each alarm can be set in a time interval between 1 and 59 seconds. Sample applications:

- 1) Activating an acoustic signalling device for industrial applications<sup>4</sup>, signalling, for example, a break or a shift rotation in an industrial plant;
- 2) Activating a school bell;
- 3) Giving a time signal to separate systems or devices.

### 8.1 Executive relay parameters

Embedded executive relay parameters	
Types of contacts	NO (normal open)
Maximum load	5A
Maximum applied voltage	230V
Maximum applied power	1000W

Table 3

There is a possibility to connect a different signalling device (e.g. visual or visual-acoustic) to the relay connector. In such case, be careful not to exceed the relay electric parameters.

<sup>4</sup> Optionally, an audible signalling device is available.

## 9 Additional options

### 9.1 IR remote control unit

IR remote control unit (Fig. 5), enables entering the embedded user menu. You can do it by pressing the „MENU” button (Fig.5, det. C)

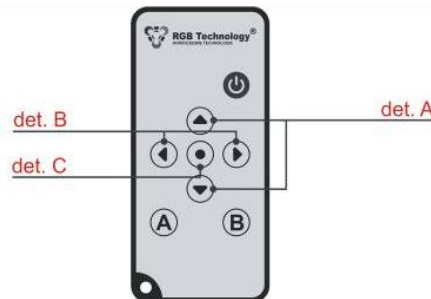

det. A – arrows for changing the parameters (UP/DOWN); det. B – proceeding to the next position (BACK/NEXT)  
det. C – „MENU” button

Fig. 5

The detailed description of the user menu functions is available in the DTR manual of this device.

### 9.2 PoE power supply

Optionally, the clock can be powered-up through the LAN connector (PoE). Choosing this power supply option requires using a power supply device meeting the IEEE 802.3at standard.

### 9.3 GPS module

Optionally, the device may be equipped with an external GPS module. The properly configured clock equipped with the GPS module can synchronise the displayed data with a satellite. The detailed description of the module is available in the DTR documentation of the GPS module.

### 9.4 Temperature sensor

The temperature sensor (Fig. 6) is available with two versions of a signal cable length 0.5m and 2m..

The probe enables measuring and displaying temperature only in °C (Celsius). The detailed description of the temperature probe is available in the DTR documentation according to the catalogue index number.



Fig. 6

### 9.5 Audible signalling device

Optionally, the device is equipped with an audible signalling device. The user may choose one of two signalling device versions:

- 1) volume of the audio signal at the level of 88dB;
- 2) volume of the audio signal at the level of 108dB.

The detailed description of the signalling device is available in the DTR documentation according to the catalogue index number.

## 10 Initial start-up

Step 1: Connect the device to 230V power supply,

Step 2: Properly connected system should display pre-set (current) time and date.

## 11 Disposal and recycling

### 11.1 Recycling of packing materials

The packaging materials must be segregated , then recycled in accordance with local regulations for waste disposal regulations.

### 11.2 Disposal of the device

The device can not be disposed with regular household waste!

According to Directive 2002 / 96 / EC ( WEEE ) , when repair is not economically reasonable, user is obligated to hand over damaged or destroyed device to an appropriate disposal facility .



## 12 Most common installation errors

1. Device installed contrary to the instructions.
2. Drilling additional holes in the casing.
3. No plugs in unused holes of the extender box.